

# Increasing Abstraction and the Rapid Adoption of Complex Technologies

---

Willy Shih

Robert & Jane Cizik Professor of Management Practice



**HARVARD**  
**BUSINESS SCHOOL**

21 May 2021

Technology-Enabled Disruption

1

Q: How can so many new technologies be adopted so quickly?

How do we explain the speed of knowledge dispersal?

## Increasing the Level of Abstraction as a Strategy for Accelerating the Adoption of Complex Technologies

Willy C. Shih<sup>a</sup>

<sup>a</sup> Harvard Business School, Boston, Massachusetts 02163  
Contact: wshih@hbs.edu,  <https://orcid.org/0000-0002-8089-1127> (WCS)

Received: September 6, 2019  
Revised: March 24, 2020  
Accepted: September 25, 2020  
Published Online in Articles in Advance:  
February 3, 2021

<https://doi.org/10.1287/stsc.2020.0116>

Copyright: © 2021 INFORMS

**Abstract.** Many new technologies are complex and embody high levels of technical sophistication, and applying them should require significant knowledge and experience. Yet, the rapid adoption and incorporation of these technologies into other innovations seems inconsistent with the expertise needed to make them work. In this paper, we propose increasing levels of abstraction as a strategy for speeding the adoption of new technologies. Higher-level abstractions package complexity in ways that makes them easier to understand and recombine, and they decrease the resources needed by firms to deploy sophisticated technical know-how. Increasing the level of abstraction is a way to push forward the innovative frontier by making such difficult-to-use technologies readily accessible to other innovators. Although this framing has been used in engineering and software development to describe modular encapsulation and cumulative innovation, we propose its use in the management literature to describe more broadly the uptake of new technologies and their facile recombination. This framing casts a different light on cumulative innovation and exposes new managerial questions to explore

**Funding:** Financial support from Harvard Business School's Division of Research and Faculty Development is gratefully acknowledged.

**Keywords:** diffusion of innovation • technological change • technology and innovation management • technology strategy

Technological change lies at the heart of economic growth (Romer 1990), and we live in an era in which many new technologies are incorporated into products and services at an extraordinary pace. New technologies build on a foundation of knowledge and inventions laid out by earlier innovators (Nelson and Winter 1982, Scotchmer 1991, Caballero and Jaffe 1993), and many innovations today are remarkably complex and embody high levels of sophistication. For example, 4G-LTE or 5G wireless telecommunications protocols employ flexible and spectrally efficient radio-link technologies (Larmo et al. 2009, Agyapong et al. 2014, Gupta and Jha 2015) that require highly trained radio engineers many years to develop. Yet, once they are embodied in semiconductor chip sets, smartphone manufacturers can incorporate them within a single design cycle, usually lasting less than a year. Innovations like smartphones that rely on these technologies, in turn, have become platforms upon which a multitude of other new products and services are built, and their speed of adoption is much faster than would be expected if firms had to develop in-depth understanding and working knowledge of the underlying computing and communications technologies before being able to replicate them. Innovators, thus, are able to shortcut the requisite organizational learning and capability

building that faced the pioneers, and this fosters broad and faster diffusion of new technologies. This paper seeks to illuminate a mechanism for this knowledge transfer and bridge a gap in the management and innovation literature by arguing that increasing the level of abstraction can be framed as a deliberate strategy that innovators use to enable the rapid adoption of new technologies and facilitate recombinant innovation.

The innovation literature is rich with the analysis of learning and knowledge transfer. Central to the adoption and use of new technologies is the development of an understanding of the technical foundations coupled with the ability to internalize and use the knowledge embedded within them (Cohen and Levinthal 1990). Knowledge transfer is a central competitive dimension of what firms do (Nelson and Winter 1982, Kogut and Zander 1992, Zander and Kogut 1995, Schumpeter 2013) and contributes substantially to organizational performance (Epple et al. 1996, Argote and Ingram 2000). Such transfers represent efforts to create partial or exact replicas of complex practices (Lippman and Rumelt 1982) and often entail understanding a web of relationships that connect specific resources (Szulanski 2000). Difficulties experienced in such transfers connote stickiness (von Hippel 1994, Szulanski 1996), which drives the often-heavy resource costs associated with such transfers (Tece 1981).

## Central to the adoption of new technologies are:

- An understanding of the technical foundations
- The ability to internalize and use the knowledge

## How do we codify the knowledge so that we can use it effectively?

- Including especially tacit knowledge

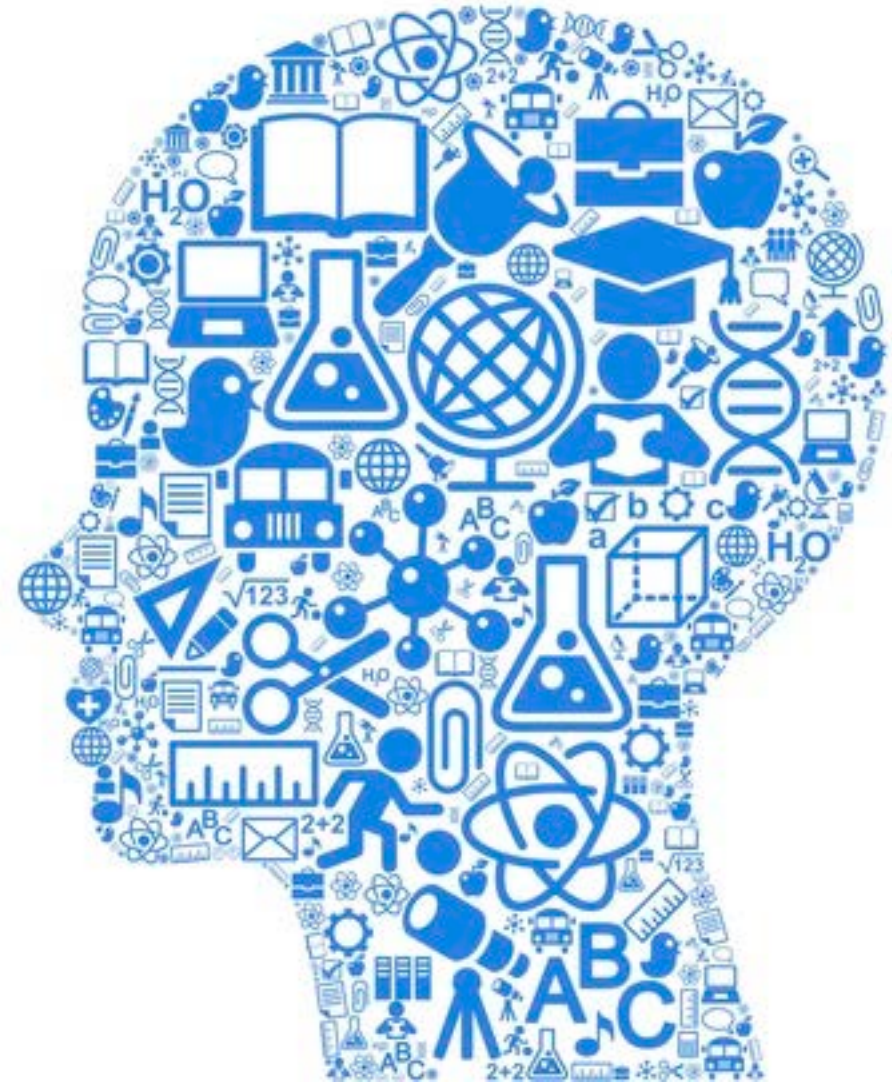

# “Abstraction”

---

Philosophy: Separating ideas from their spatial or temporal qualities

Mathematics: Extraction of underlying patterns and structure of a concept, while removing dependence on physical objects, leading to a generalization

Engineering: Identifying a pattern, naming and defining it, finding ways to specify it, and providing *a way to reuse it*

- In software, abstraction is associated with language constructs, specification techniques, program structures such as algorithms and data types, and strategies for modular decomposition
- Allows representation of phenomena in terms of limited number of “essential” elements rather than in terms of concrete features

Containers



Classes & Objects



Object-Oriented Language



Higher Level Language

Assembly Language

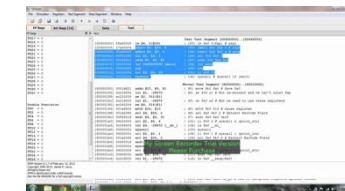

Machine Language

Instruction
0010 0000 0000 0100
0001 0000 0000 0101
0011 0000 0000 0110
0111 0000 0000 0001
0000 0000 0101 0011
1111 1111 1110 1001
0000 0000 0000 0000

- A software developer cannot deal with more than a few concepts and their relationships simultaneously
  - Abstraction suppresses the details, and simplifies the understanding of the result
- If knowledge is hidden or encapsulated within a module, that knowledge need not be communicated to other parts of a system
- Development of abstraction techniques has been a major source of improvement in programming practice

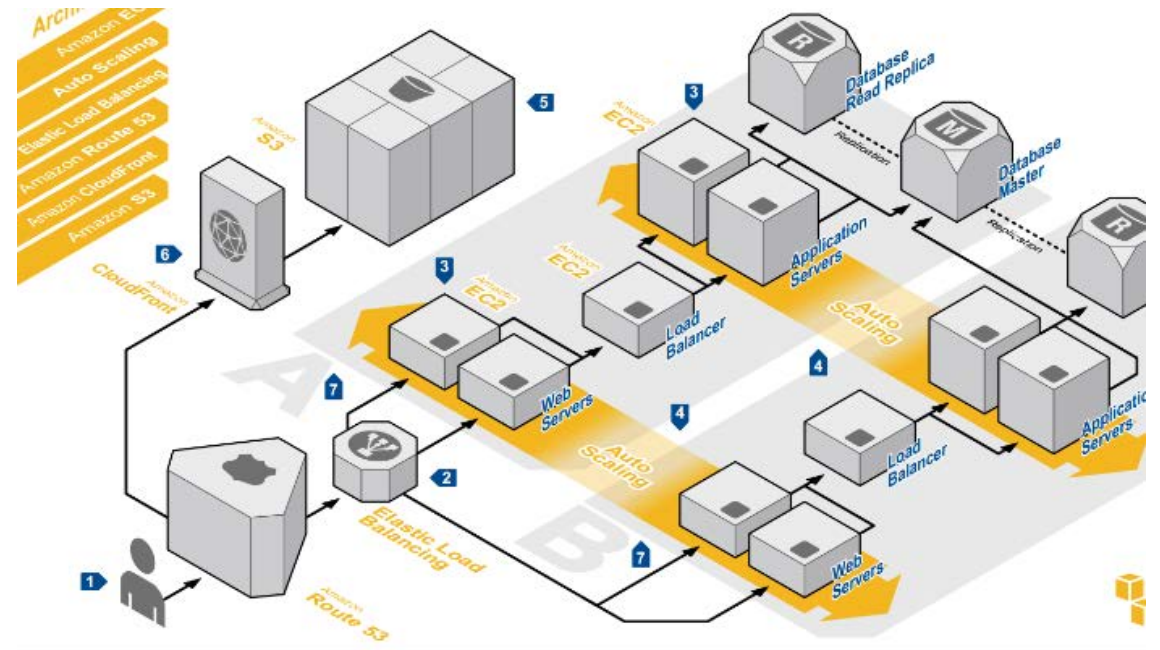

# Abstractions Codify Knowledge

- Codification is an exercise in abstraction that economizes on bounded rationality. Instead of having to respond to a hopelessly extensive and varied range of phenomena, the mind can respond to a much more restricted set of information



Ride-sharing app developer like Uber does not need to understand how Google Maps is built, or how the underlying 4G LTE/5G data stream is provisioned

## *Key benefits*

- Enables designers to conceptualize at a higher level
- Recombination with knowledge that is foreign (distant) to the designer

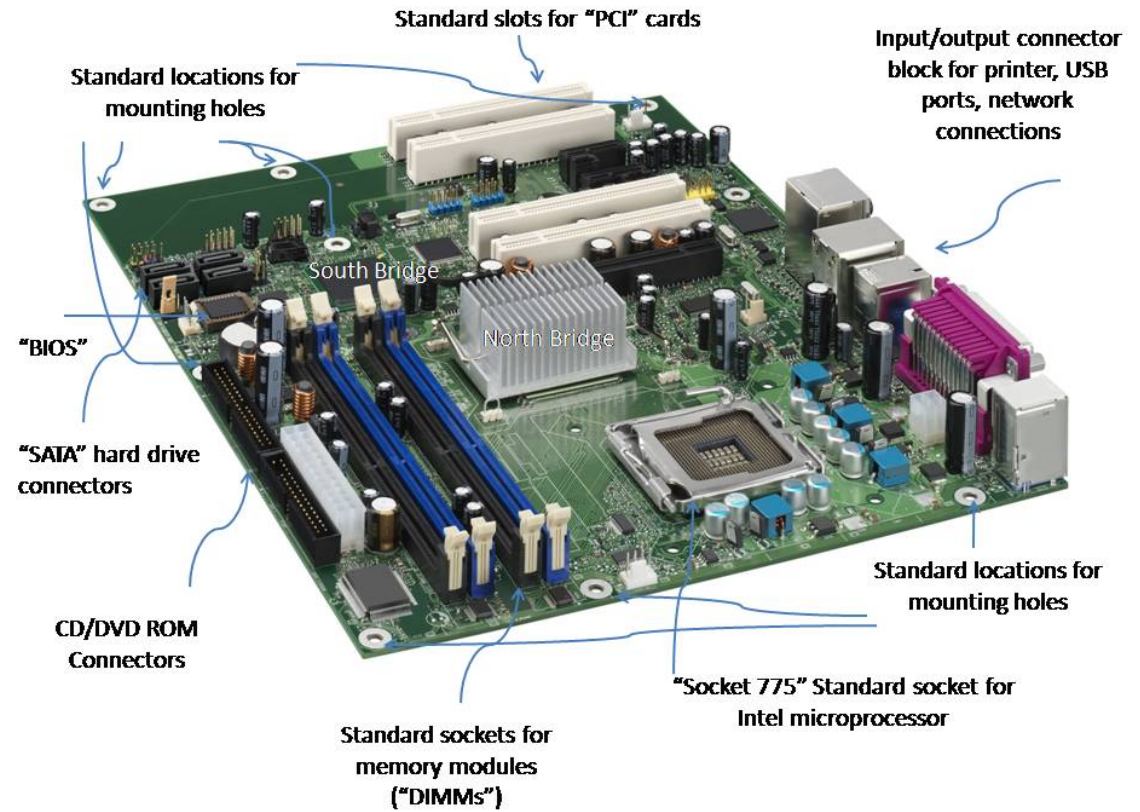
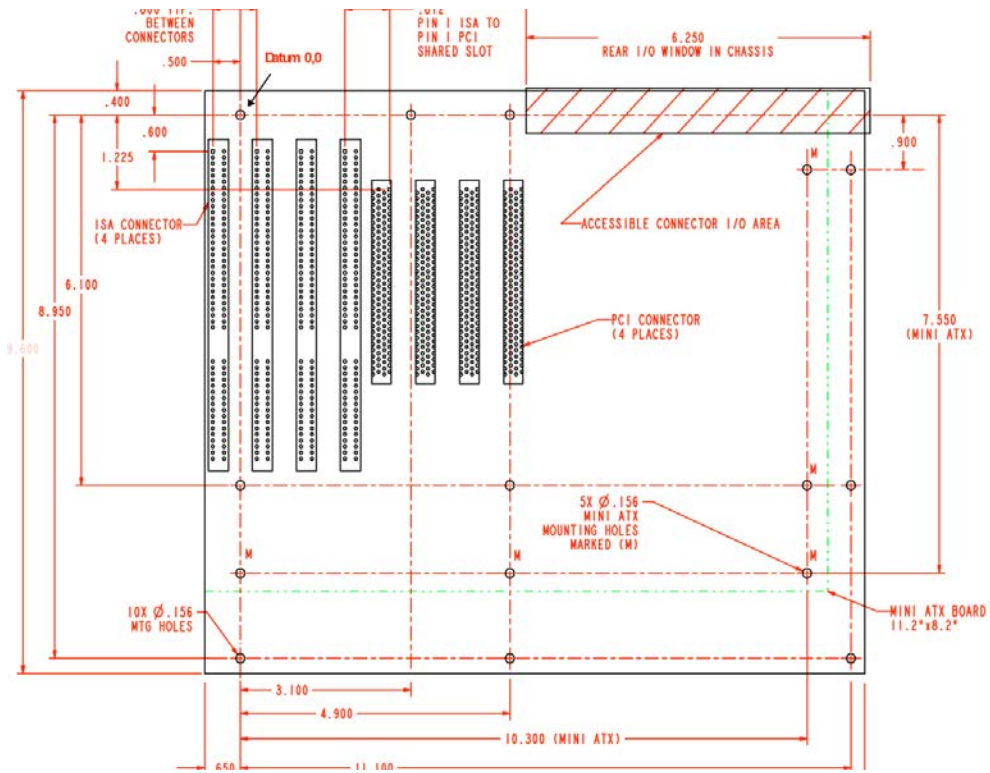



# Raising the Level of Abstraction



Easy to “transfer” knowledge, to embed it in new innovations

## *General Purpose Platforms*

- Raise the level of abstraction and enable new recombination with distant information

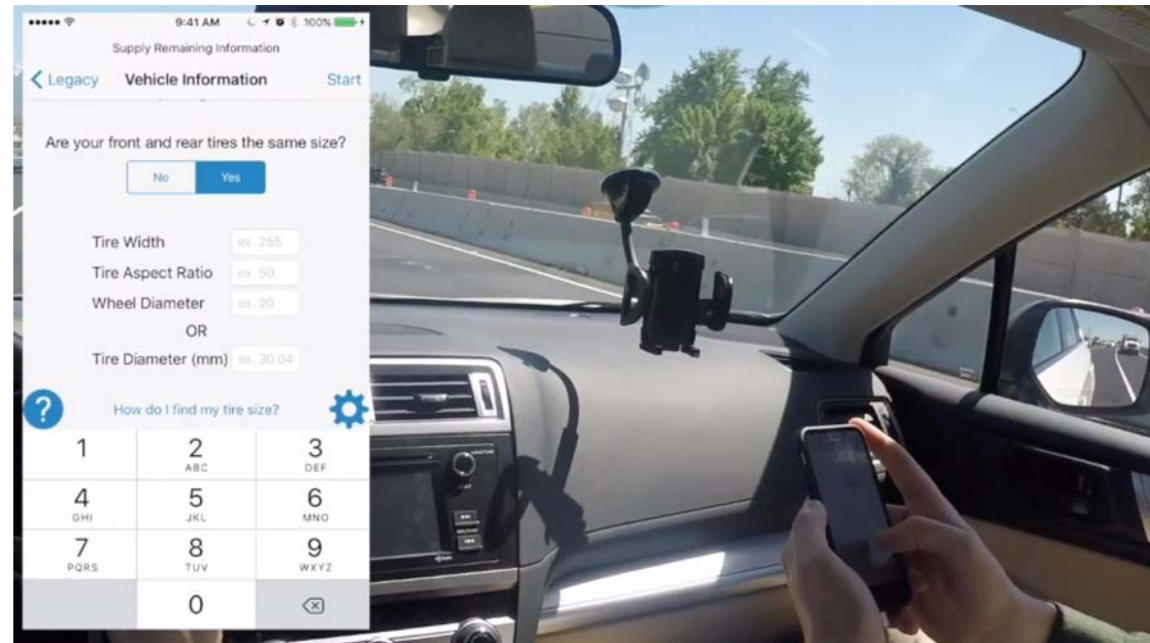



21 May 2021

# Higher Abstraction Levels Enable Easier New Recombination

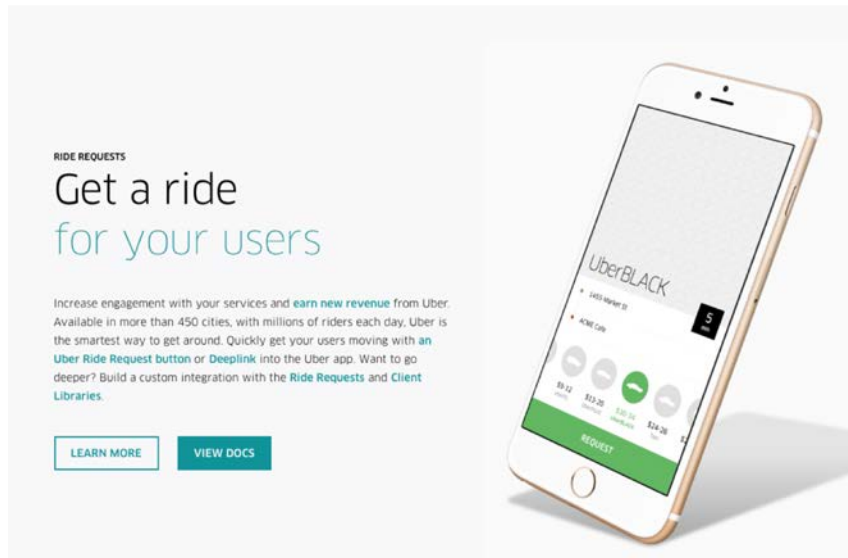

Uber app is built on top of iOS, Android APIs + Google Maps

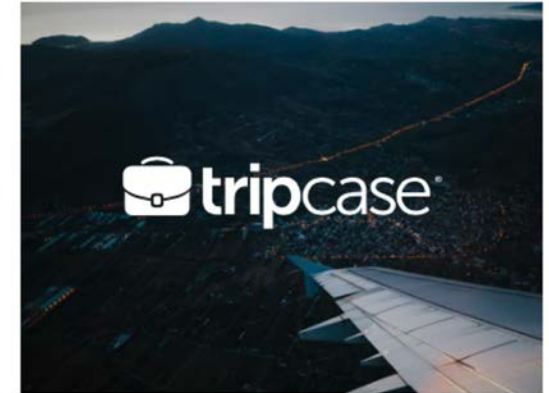
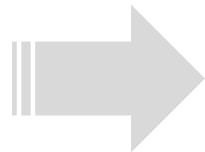

Uber in turn raises the level of abstraction to a modular ride service, and offers a higher level API to other innovators

# Amazon DeepLens

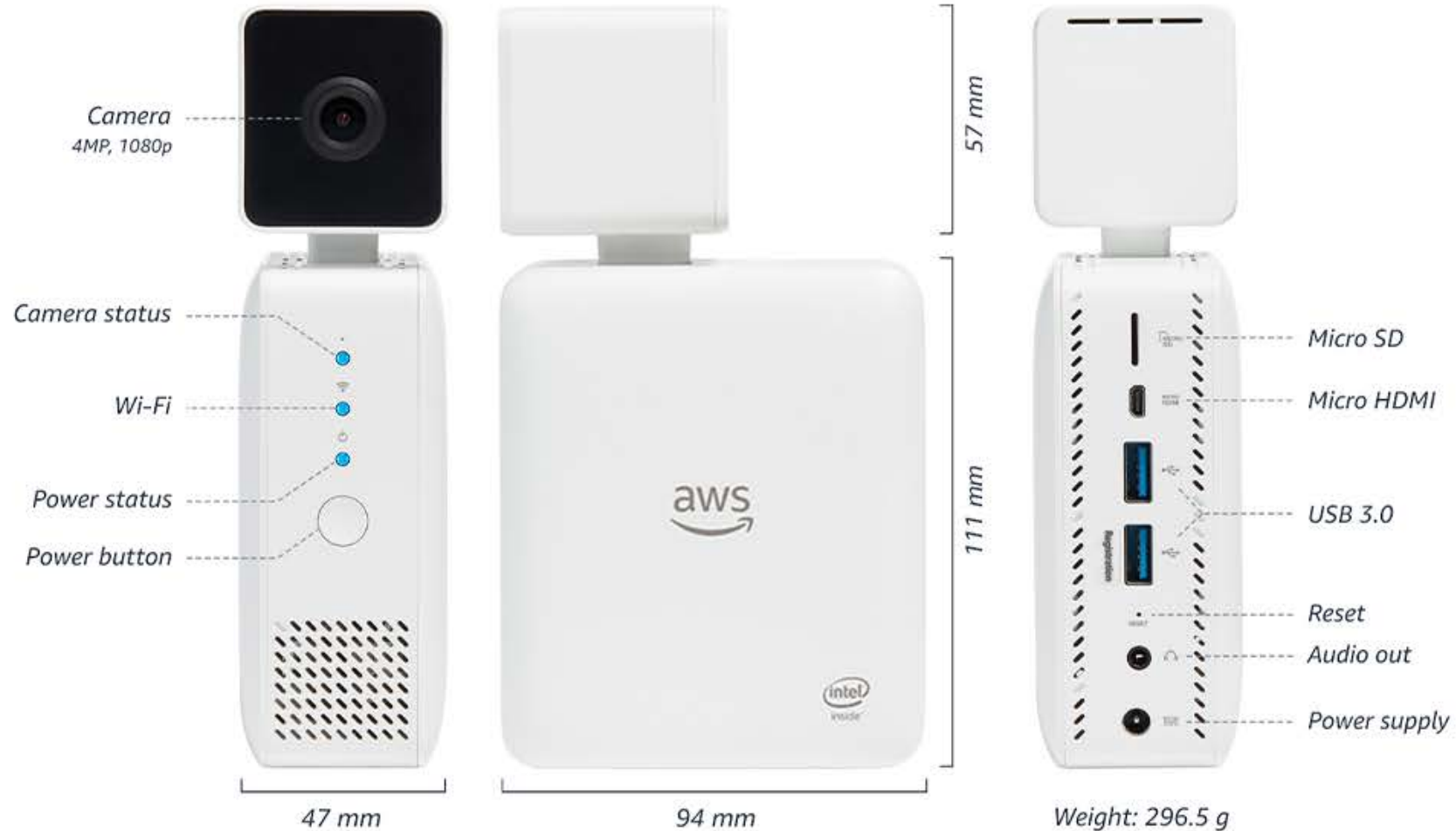

# Amazon Rekognition

## Add image and video analysis to applications

- Free tier  $\Rightarrow$  5000 images/month for 12 months

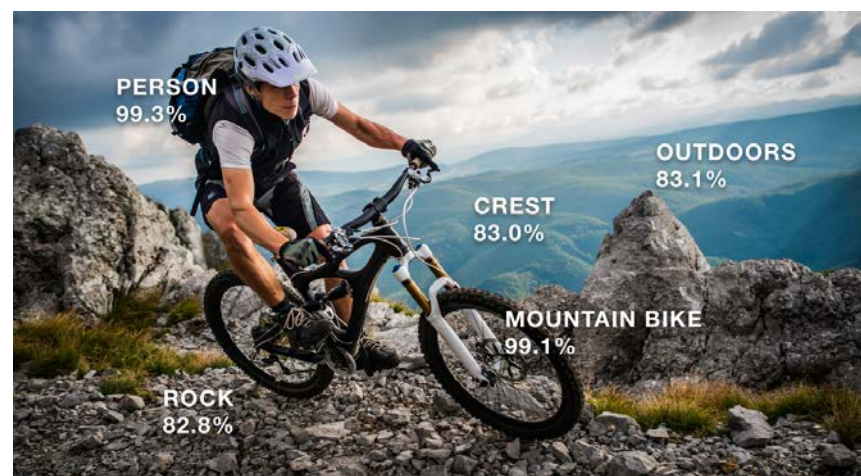

Label from video

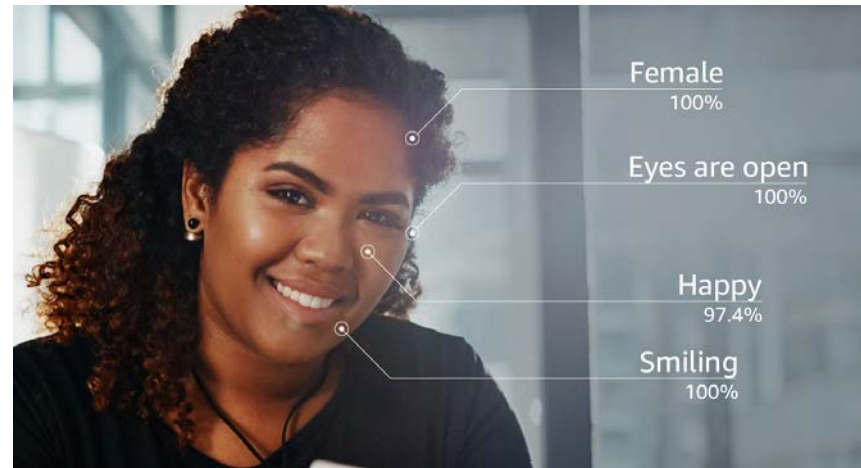

Face detection and analysis

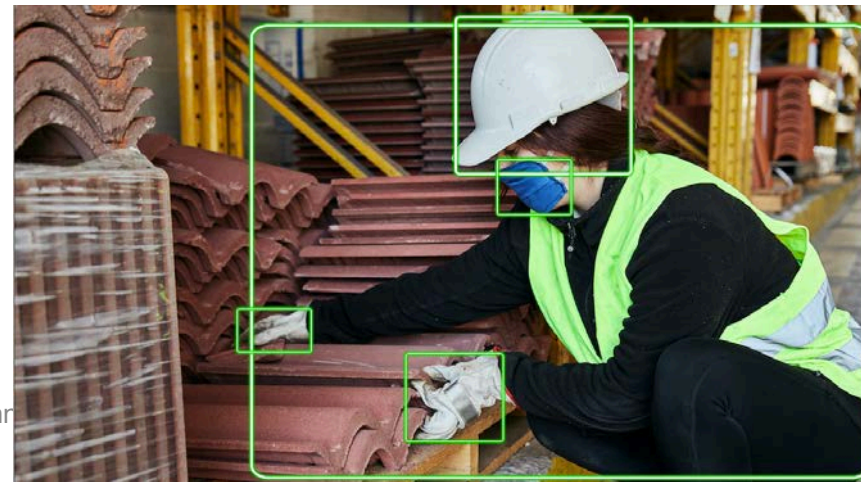

PPE Detection

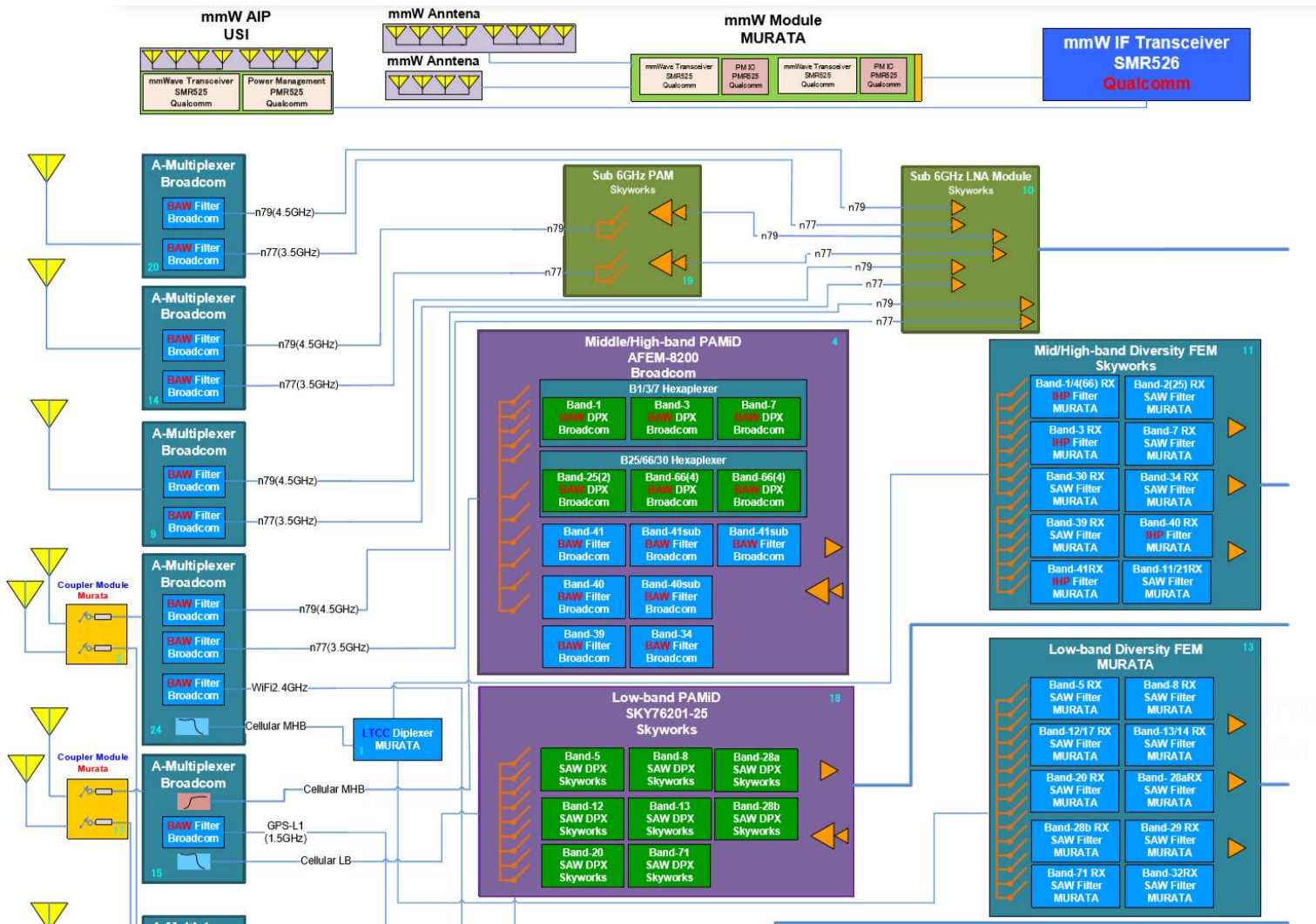

# Abstraction and Know-How Embodiment

- A procedure becomes routinized and repeatable
  - It can be broken down into component pieces, each of which is sufficiently simple that it can be described verbally or embodied in a machine
- For example, semiconductor manufacturing tools embody abstractions, *e.g.*, lithography, CMP, deposition, etch

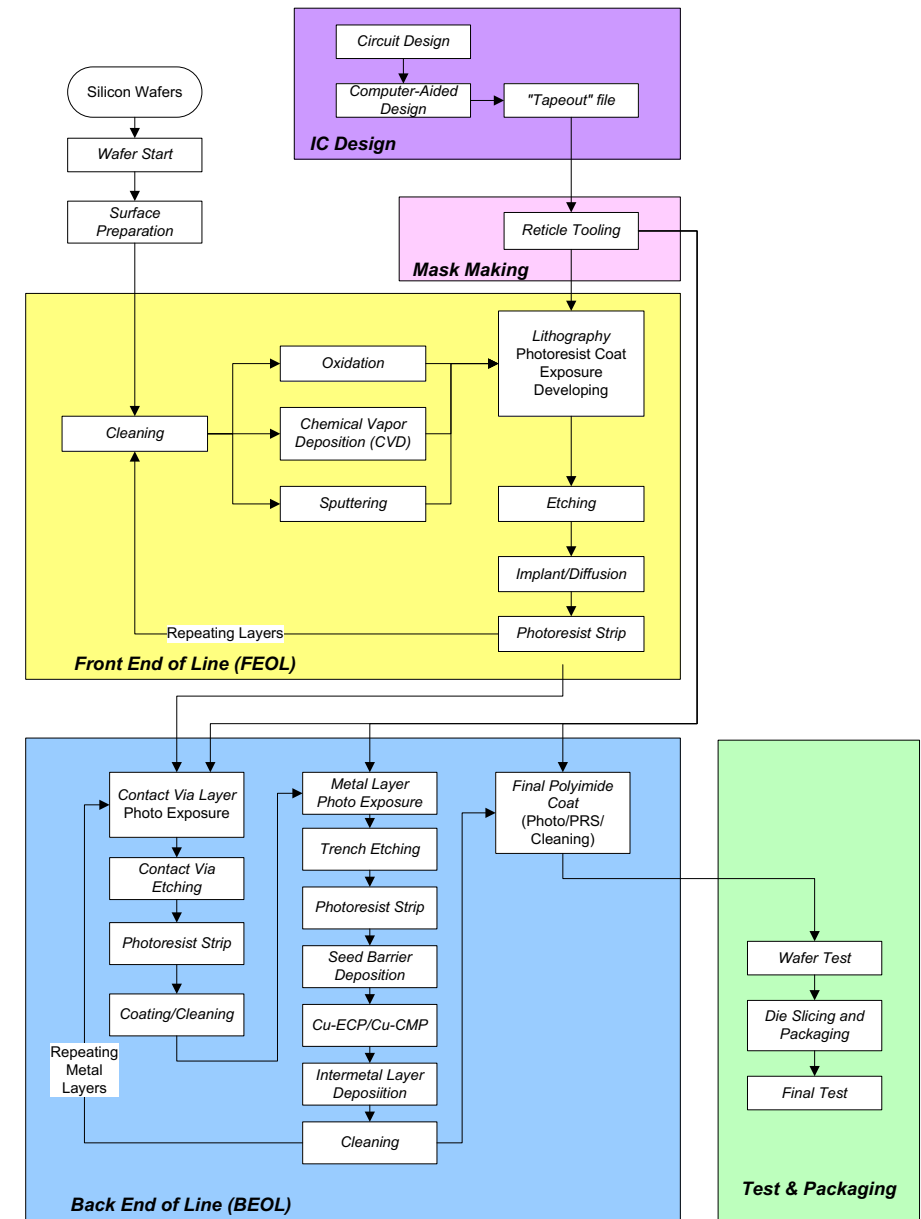

TSMC N65 Process

# Raising Abstraction Level in Semiconductor Design

- IP blocks are a widely used abstraction in IC design
- The *Design Foundry* raises the level of abstraction, incorporating hierarchical building blocks in its own workflow construction – no need to understand the complex underlying details
- Significantly lowers costs and entry barriers

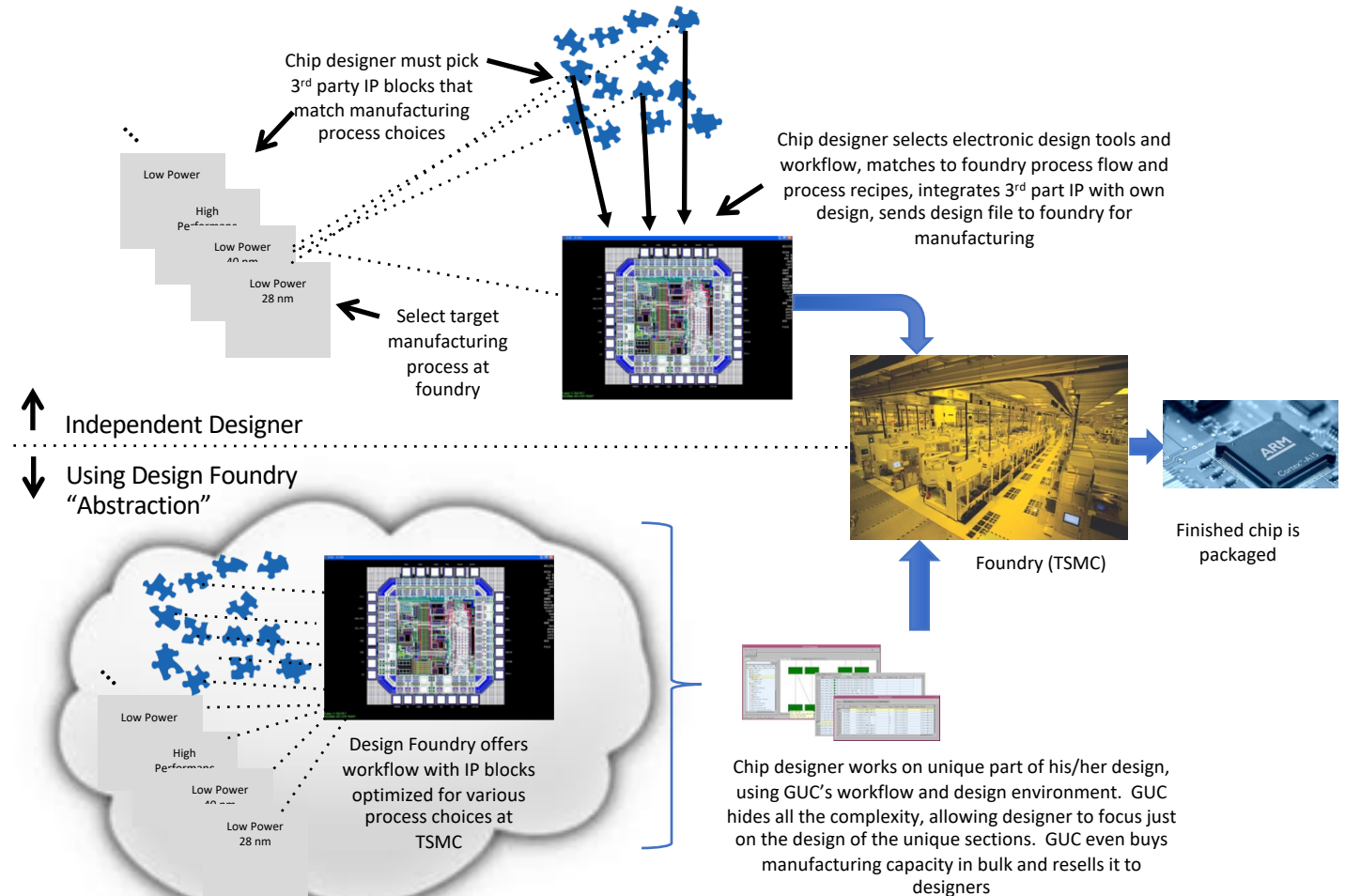



# Perspective on Knowledge Flows and Recombination

- Knowledge embodiment in, and flow through tools
  - Production tools and design tools
- Diffusion of new processes in iron and steel-making tracked addition of new capacity that embodied major innovations leading to quality improvements and/or cost



United Shoe Machinery Company and its network of subsidiaries acted as a diffusion system for innovations

- Pioneered the technological modernization of shoe manufacture
- Since it pursued international expansion, innovations developed in the United States did not take long to reach Europe.

By Tichnor Bros. Inc., Boston, Mass. - Boston Public Library Tichnor Brothers collection #67589, Public Domain, <https://commons.wikimedia.org/w/index.php?curid=46206166>

# Case Study: TFT-LCD Manufacturing

## *Via Tool Vendors*

- Propagation of one drop filling technology
- Propagation of Fab operations techniques

## *Sequential study of Gen 5 Fab Facilities*

- Acer, Chi Mei, Sanyo, Epson, Samsung, LG, BOE, SVA

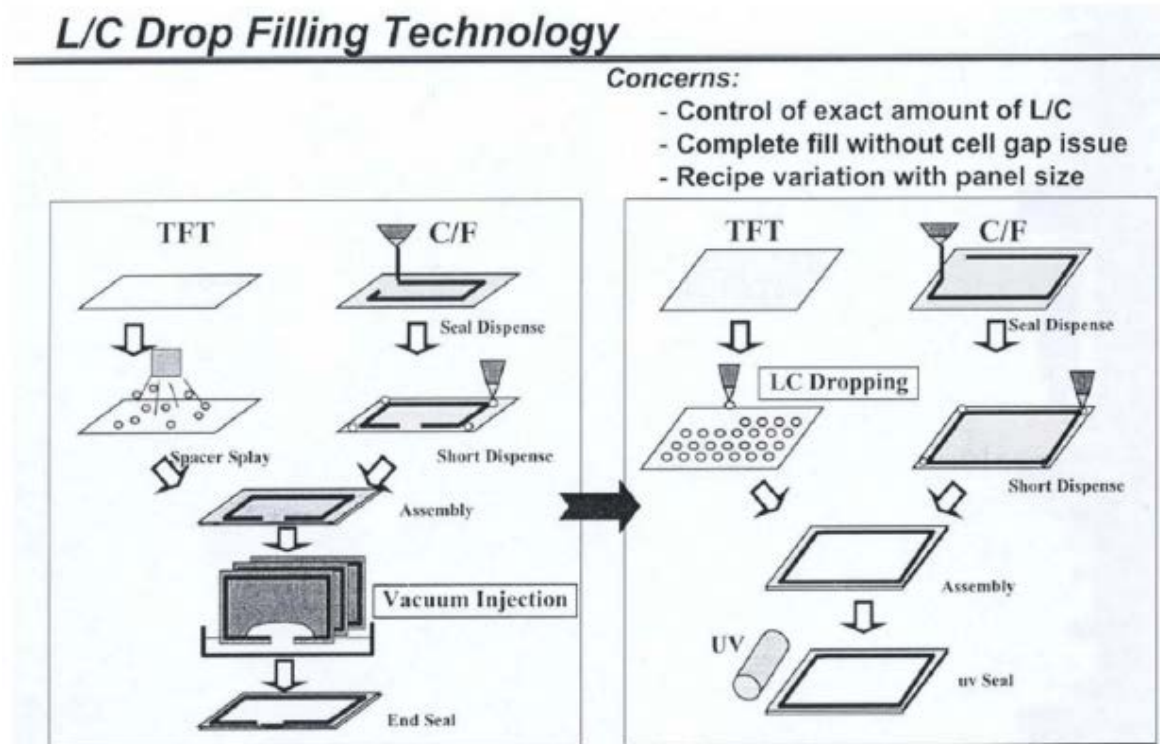

# Case Study: LED Manufacturing Industry

---

- Essential role of metal-organic chemical vapor deposition (MOCVD) tool
- Two key tool suppliers
  - AIXTRON
  - Veeco Instrument
- Chinese government 100% subsidies led to overcapacity and commoditization of low to mid-range LEDs by Chinese manufacturers



# Tool Makers: A new tool *is* the product

---

- Tool makers (capital goods suppliers) acted as a medium to pass information about a new technology back and forth among users
  - To the tool manufacturers, a new machine was a *product* invention, and they could only capture the profits of its invention by selling it to their customers, the tool users. Profits depended on product's diffusion
- Tool makers have the financial incentive and therefore provide the pressures (marketing, demonstration) to persuade firms to adopt the innovations they produce
  - Creating a capital goods industry is, in effect, a major way of institutionalizing internal pressures for the adoption of a new technology



# Implications

---

## Speed of innovation enhanced

- Enables new players to capitalize on many years of R&D performed by others
- Levels the global playing field

## Recombination on top of platforms (key abstractions, cheap building blocks)

- Compute + always on connectivity + touch interface
- Remarkably easy to implement machine learning and artificial intelligence applications

